



CopyCam

Image Capturing System



Increase Your Productivity in an Instant

Ideal for highly collaborative workers, CopyCam® Image Capturing System changes an ordinary whiteboard into a copyboard, enabling instant capture of notes or drawings.

CopyCam's user-friendly and one-touch process saves time, eliminates the problem of recalling meeting content, and increases productivity in the workplace. Meeting participants simply take notes and sketch the way they would on any standard whiteboard; no pre-planning or computer is required. When ready to capture notes or drawings from the whiteboard, pushing one of three buttons on the control pad instantly saves the image to an internal archive on the LAN, saves to a portable USB drive, or prints to a networked printer.

Two Easy-to-Use Versions

CopyCam Image Capturing System is available in two easy-to-use versions to support the work practices of any collaborative environment.

CopyCam Pro has a three-button control panel allowing users to capture notes and save to the LAN, save to USB, or print to a networked printer at the touch of a button.

CopyCam E offers the same benefits as CopyCam Pro, but has a streamlined (one-button) control panel. When ready to save your notes, just press one button to capture in full color and save to the LAN.

Features and Benefits

- Save notes and sketches in four colors from any whiteboard
- Print to a networked printer (included)
- Save to a portable USB drive or to an internal archive on your local area network (LAN)
- Instantly email notes or images to meeting attendees using One-Click Publishing™
- Optional one-button format for save-to-web only
- Track image and note captures with automatic date and time stamp
- Attach flipcharts or other handwritten material to the whiteboard and capture them along with the notes written on the board
- Distribute notes electronically using One-Click Publishing or by saving to the LAN – use less paper and reduce your impact on the environment



CopyCam Pro



CopyCam E

RoomWizard™ and One-Click Publishing™

Adding the RoomWizard Room Scheduling System (RW 10) and One-Click Publishing to CopyCam enables you to automatically email notes to meeting attendees in three simple steps:

1. Use RoomWizard to schedule your meeting time and location, and to invite attendees.
2. Create and capture notes and sketches with CopyCam.
3. With the touch of a button, RoomWizard compiles meeting notes and automatically emails them to each attendee at the end of a session. Notes appear the same as they did in the meeting, enabling retention of contextual memory and promoting more efficient meeting follow-up.

Integrating RoomWizard with CopyCam's note-capturing technology enables you to easily pick up where you left off and move forward in your next meeting.

Companion Premium Whiteboards

CopyCam is compatible with any markerboard up to 48" x 96" (1200mm x 2400mm). Designed with CopyCam in mind, Premium Whiteboards enable cables to be easily routed and concealed.

PolyVision's Premium Whiteboards featuring *e³ environmental ceramicsteel™*, are the first and only ecologically intelligent whiteboards and writing surface to receive Cradle to Cradle™ Silver certification. Adding a Premium Whiteboard to the CopyCam Image Capturing System provides an aesthetic, as well as functional and environmentally responsible solution for your collaborative space. Recommended companion boards include:

- Edge™ with champagne trim; 48" x 96" (C-ED-M-084-T020)
- Mystic™ Metal with champagne trim; 48" x 96" (C-MIM-M-084-T020)

To add cable management between the whiteboard and the CopyCam control pad, choose a Cable Management Bridge for either the left or right side of the whiteboard.

- 0040071-CG: Right side bridge for CopyCam Pro
- 0040072-CG: Left side bridge for CopyCam Pro
- 0040074-CG: Right side bridge for CopyCam E
- 0040075-CG: Left side bridge for CopyCam E

Mobile Surface Solution: Huddleboard™

Lightweight, portable, and versatile, Huddleboard is a portable whiteboard solution that can be easily placed under the CopyCam for image capture then moved away for use elsewhere. Huddleboard, when used with CopyCam, provides flexible and multiple solutions for your working or learning environment.



RoomWizard Room Scheduling System



One-Click-Publishing note capture and distribution



Mistic Metal Premium Whiteboard



Left side bridge for CopyCam Pro



Huddleboards on a mobile easel

CopyCam

Technical Specifications

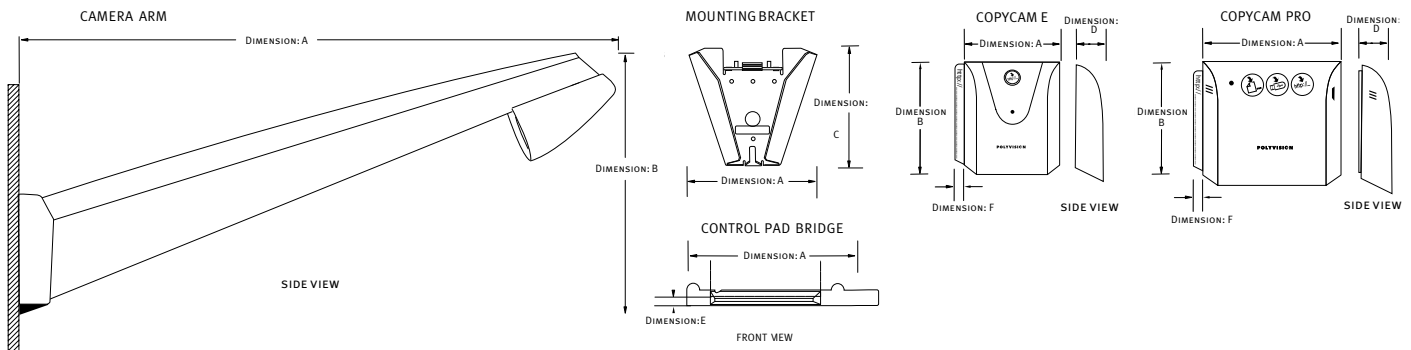

| Dimension | Camera Arm | Mounting Bracket | CopyCam E | CopyCam Pro | Control Pad Bridge (E) | Control Pad Bridge (Pro) |
|--------------------|-----------------|------------------|-----------------|-----------------|------------------------|--------------------------|
| A (Width) | 38" (965.2mm) | 7.5" (190.5mm) | 4.62" (117.3mm) | 7.87" (199.9mm) | 8.62" (218.6mm) | 11.87" (301.5mm) |
| B (Height) | 13.5" (342.9mm) | | 5.75" (146mm) | 6.12" (155.4mm) | | |
| C (Bracket Height) | | 6" (152.4mm) | | | | |
| D (Depth) | | | 1.62" (41.1mm) | 1.75" (44.5mm) | | |
| E | | | | | .5" (12.7mm) | .5" (12.7mm) |
| F | | | .5" (12.7mm) | .5" (12.7mm) | | |

Camera Arm

- 3.5 megapixel resolution
- Captures line drawings and writing in any color
- Enhances contrast for crystal clear copies
- Automatically crops copies to board borders
- Jacks for power, LAN, and control pad

Control Pad: CopyCam Pro

- 3-button interface allows direct capture to printer, USB, or built-in Web server
- Weighs less than 2 lb (.75kg)
- Voice prompts and 3-color LED provide status

Control Pad: CopyCam E

- 1-button interface allows direct capture to web server
- Weighs less than 1 lb (.375kg)
- Voice prompts and 3-color LED provide status

Printer

- Network-enabled color printer included

USB Drive

- Writes images to a standard USB drive (with FAT partition)
- Each 10MB of drive space holds approximately 70 images

Built-in Web Server

- Holds approximately 40 images
- Can be accessed from anywhere on a LAN using standard web browser
- Images are retained if there is power loss
- Supports fixed IP addressing or DHCP protocol

Power Requirements

- 100-240VAC, 50-60HZ, 18W
- Energy Star® Level IV compliant

Certification

- FCC Class A, UL60950, CSA60950

Warranty

- One-year limited warranty
- Extended warranties available

Accessories (Included)

- Network-enabled color printer
- User Guide
- Installation manual
- Mounting templates
- Power adapter with 15' (4.6m) cord
- 15' (4.6m) Ethernet cable
- 10' (3.04m) cable from arm to control pad
- 24' (7.32m) of cable raceway in 4' (1.22m) sections
- "Tilt-up" mounting bracket for camera arm
- 17' (5.1m) power supply extension cable

Simple. Effective. Extraordinary.
The way communication should be.



Environmental Policy: PolyVision strives for continuous improvement in all areas of environmental stewardship – responsible use of raw materials and natural resources, design processes and operation of all facilities – to protect, replenish, and restore the communities in which we live and serve.

PolyVision Corporation

1.800.620.POLY

www.polyvision.com

info@polyvision.com

PolyVision®
A Steelcase Company

©2007 PolyVision Corporation. All rights reserved. Trademarks used herein are the property of PolyVision Corporation or of their respective owners. PolyVision Corporation reserves the right to make changes in product design, construction, or detail, and to discontinue any product or material without notice.

This document is printed on recycled paper.

07-0006359
CC_1007