

# METAMORFOSI METAPONTO

ERNESTO GISMONDI • 2001

AN OUTDOOR VERSION OF THE PATENTED METAMORFOSITECHNOLOGY BY ARTEMIDE. WITH METAMORFOSI, ARTEMIDE RESTORES TO LIGHT ITS TRUEST ESSENCE; FOOD FOR THE BODY AND FOR THE MIND, THE PROTAGONIST OF DREAMS AND REALITY, THE DECISIVE ELEMENT OF EMOTIONS AND AT THE SAME TIME, OF RATIONALITY.

- A MULTI-FUNCTIONAL LUMINAIRE COMPRISING THREE INDEPENDENTLY CONTROLLED SPOTLIGHTS, BODY IN EXTRUDED ALUMINUM AND HEADS IN DIE-CAST ALUMINUM IN GREEN POLYESTER POWDER FINISH WITH TRANSPARENT MOLDED TEMPERED GLASS IN RED, BLUE, AND GREEN
- MOUNTING ON AN ALUMINUM BASEPLATE CONTAINING A FOURTH SPOTLIGHT BODY, HOUSING THE ELECTRONIC REGULATOR AND RECEIVER. THE ADDITION OF THE RJII NETWORK OPTION ALLOWS THE CONNECTION AND SIMULTANEOUS OPERATION OF UP TO 120 LUMINAIRES
- THE THREE PROJECTORS ARE INDIVIDUALLY AND SIMULTANEOUSLY CONTROLLED BY A PATENTED MICROPROCESSOR ENCLOSED IN THE LUMINAIRE, FROM A DISTANCE. A REMOTE CONTROL ACTS ON A RECEIVER SENSOR, ALSO ENCLOSED AND CONNECTED TO THE MICROPROCESSOR
- TWELVE DIFFERENT COLOR LIGHTING ATMOSPHERES SETTINGS (VOLCANO, BOREAL, OASIS, SIDEREAL, DAWN, SUNSET, SAHARA NILE, ARCHIPELAGO, RUBY, MEDITERRANEAN AND IRELAND), AS WELL AS THE WARM WHITE SETTING, ARE PRE-PROGRAMMED IN THE MICROPROCESSOR AND CAN BE SELECTED AT ANY TIME BY SIMPLY PRESSING A BUTTON ON THE REMOTE CONTROL
- A SPECIAL "ROLLER" SETTING, BY WHICH THE TWELVE PRE-PROGRAMMED ATMOSPHERES CONTINUOUSLY ROTATE WITH A DURATION OF ABOUT TEN SECONDS EACH, TO CREATE ENDLESS CYCLE OF MUTATING COLORED LIGHT. IN ADDITION, AN ALMOST UNLIMITED NUMBER OF COLORED LIGHTING ATMOSPHERES CAN BE CREATED BY THE USER BY PRESSING THE DESIGNATED BUTTONS TO REGULATE THE INTENSITY OF EACH COLOR LIGHT PROJECTOR WITH THE ONE ULTIMATELY SELECTED REMAINING IN THE MEMORY OF THE MICROPROCESSOR UNTIL SUBSEQUENT CHANGES ARE MADE

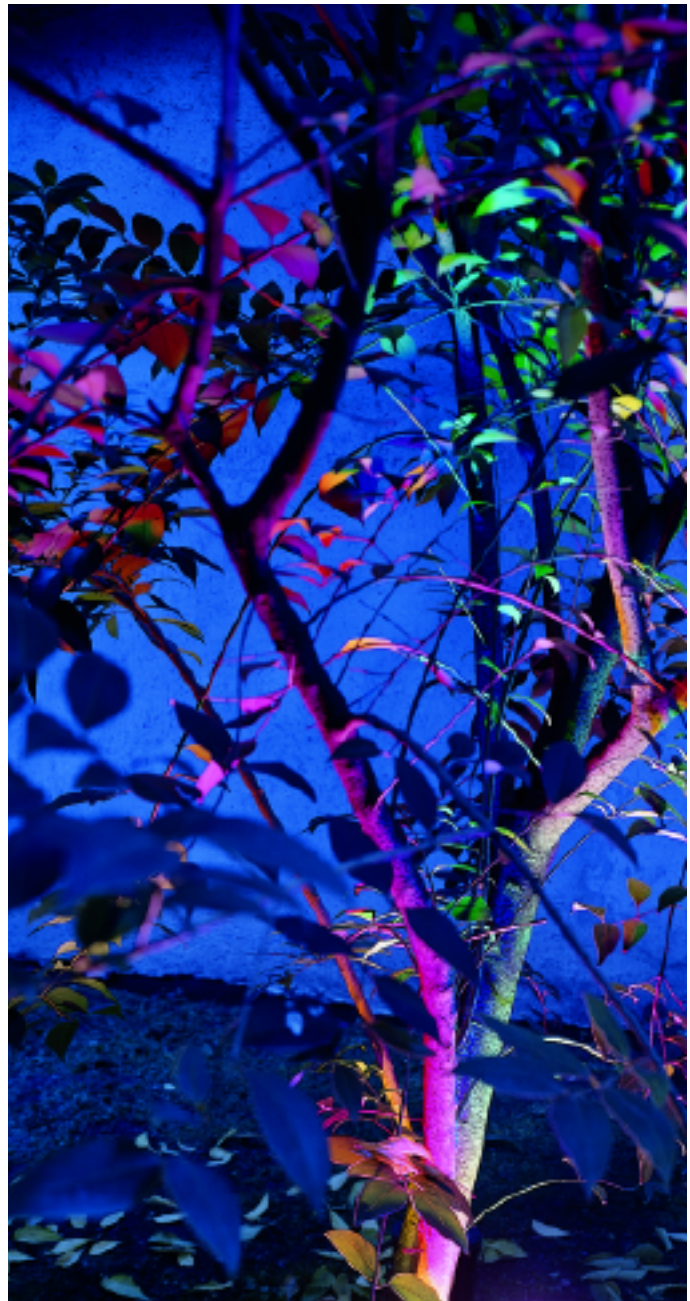
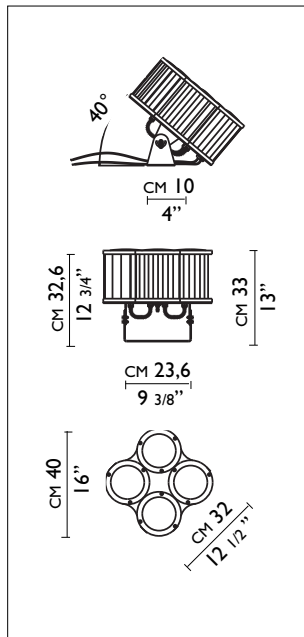

HALOGEN SOURCE

- 3X150W(B15d/T4) 