

Hanging Brackets

Primary Customer Need:

A cost-effective method of managing files on the desktop. Workers do not like to file “active” projects into drawers – “out of sight, out of mind” is a real fear in the workplace. A mechanism is needed to allow quick access physically and visually.

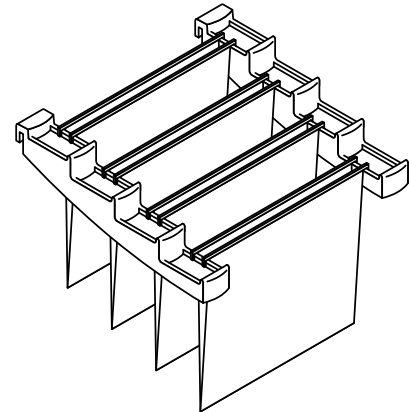

Product Features:

- Style Number: WHB
- Size: W1½ x H1¼ x D9¾
- Color: Amber, Black, Fern, Frost, Rain, or Shade.
- Construction: Open areas have been designed so product will not attract dust.
Translucent: Injection-molded engineered resin for quality and durability.
Opaque (Black): Injection-molded ABS plastic for quality and durability.
- Application: Slatwall, SlatRail panel-mounted, and SlatRail stanchion-mounted except for bottom step
- Maximum Weight Load: 5 lbs. per step (20 lbs. total)
- Warranty: 10 years
- Holds large capacity of Pendaflex™-type folders.
- Allows user to have immediate visual access to all active work.
- Dense paper/project management without using any desk space.
- Product has four steps to allow user to see all work on the brackets.
- Work is not “out of sight, out of mind” – i.e., filing fear.
- Product can hold hanging folders, Workboards, Office in a File, or any other type product designed to fit into a pedestal.
- Excellent for the project-oriented worker who must manage many activities simultaneously.
- Easy to file and easy to retrieve. No wasted time searching through jammed pedestal drawers.
- If mounted under a binder bin, this product needs a minimum 6" clearance from top step to access files in the rear.
- Product has a “stop” at each step to prevent files from dropping to a lower level.
- Product is sold only as a pair.

For a better day at work.™

details®

A STEELCASE COMPANY

www.details-worktools.com
P.O. Box 1967 Grand Rapids, MI 49501-1967
All rights reserved. Printed in U.S.A. 1/05

