

Specification Sheet

26" Straight Platform Assembly



- Style Number(s):**
QA18726EF 18" track, 26" platform, extended foam palm rest
QA23726EF 23" track, 26" platform, extended foam palm rest

QA18726EG 18" track, 26" platform, extended gel palm rest
QA23726EG 23" track, 26" platform, extended gel palm rest
- Size:** W26 1/4" x D11"
- Color:** Charcoal (5103)
- Construction:** Phenolic resin
- Application:** Support of a keyboard/mouse combination in a workstation setting
- Warranty:** 10 Years
- Specifics:**
- Platform attaches to the mechanism with the use of 4 countersunk bolts and nuts
 - Mouse surface is integral to the platform

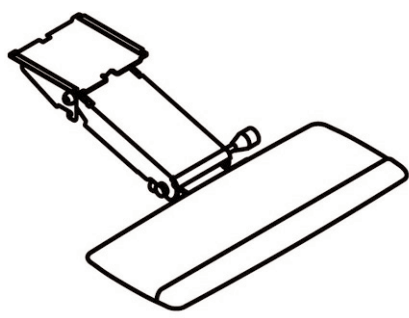

For a better day at work.™

details®

A STEELCASE COMPANY

P.O. Box 1967 / CD-5E / Grand Rapids, Michigan 49501-1967 / www.details-worktools.com

©2005 Office Details Inc. All rights reserved. Printed in the U.S.A. 04/05