

## Huddleboard™ Products

### INSTALLATION AND USER INSTRUCTIONS

PART NUMBER 93-9504755 REV. C

**Simple. And to the point.**

Easy to assemble and use.



**Hey installers!**

Please leave these instructions with the product.

{ thanks }

**Steelcase**

4 HOW to use Huddleboard Products

6 WHERE to use Huddleboard Products

8 MARKER BOARDS

Hanger Hooks, Labels, Ledge Grabbers, Flip Chart Pegs, Marker Grip

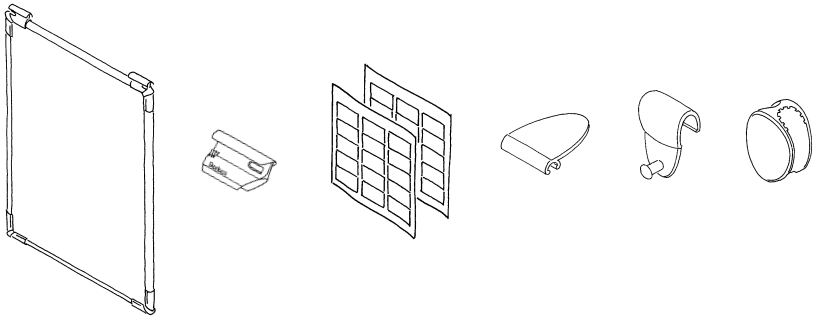

10 PHOTO ALBUM BOARD

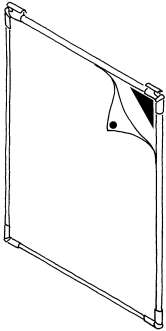

12 FOLDING EASEL

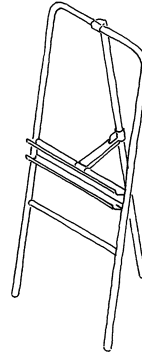

14 FREESTANDING TRAY

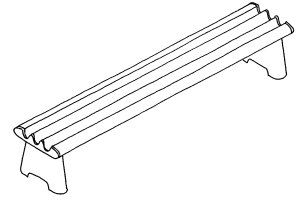

15 PANEL/STRUCTURAL TRAY

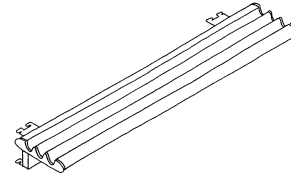

16 MOBILE EASEL

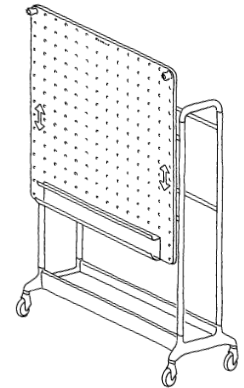

18 POSTER RACKS

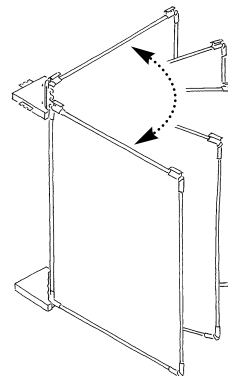

# Huddleboard Products

{CONFERENCE ROOM ON THE GO!}

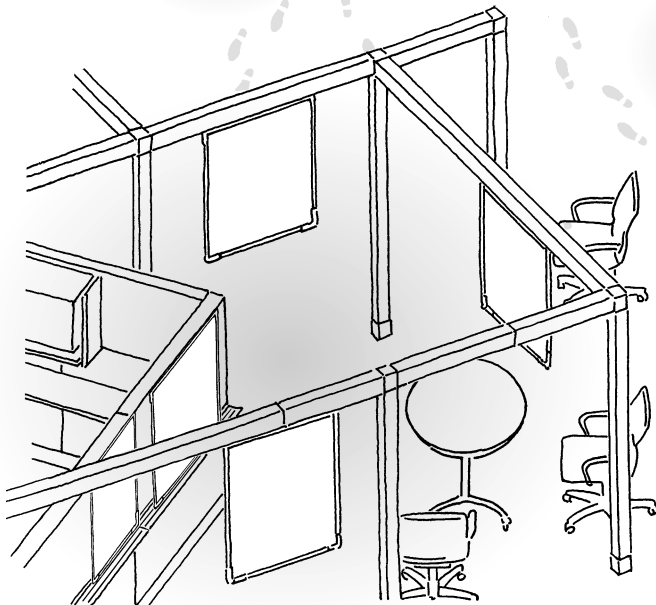
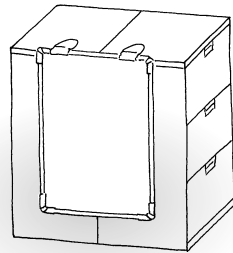
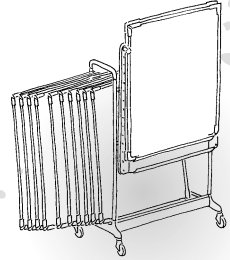
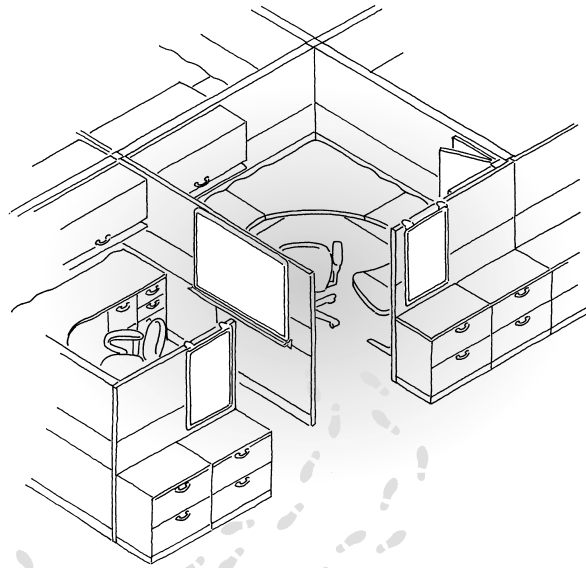

The Folding Easel is so portable that it can support impromptu meetings anytime, anywhere.

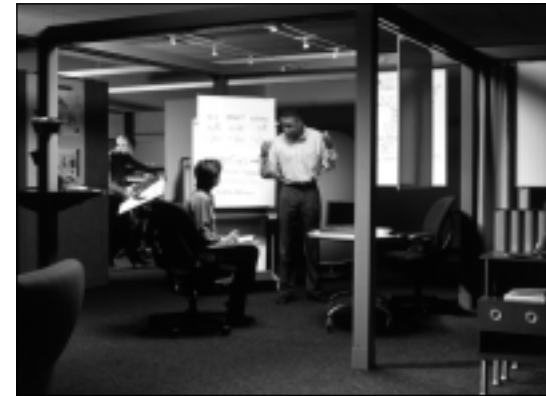

Marker Boards are so versatile you can hang them on Conjunction®, use and store up to 10 in the Mobile Easel for group work, or use them singly.



One room can now support many teams. Each group's Mobile Easel can be stored with data intact for future meetings.

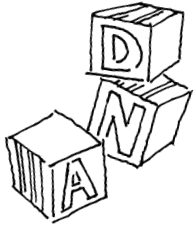

**at the office**  
(from nine to five)

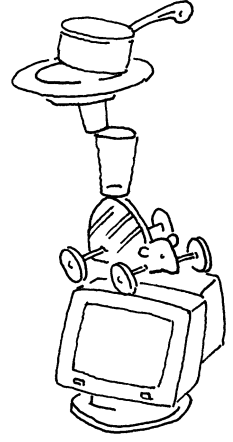

**in school**  
(from pre-school to med-school)



**at home**  
(from playroom to sunroom)

**for retail**  
(from hardware to menswear)

**coaching and teaching**  
(from little league to major league)



**in restaurants**  
(from appetizer to dessert)

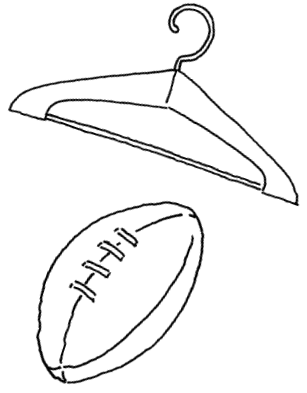

...to let us know  
the creative ways you're using  
Huddleboard Products...  
at [steelcase.com](http://steelcase.com)

To receive the Huddleboard Products brochure call:  
1.800.333.9939

**Attaching Hanger Hooks**

Necessary for hanging Marker Boards on rails, Conjunction®, Poster Rack and attaching Ledge Grabbers. Hooks can be hung in horizontal or vertical orientation.

**Step 1:** Remove boards and Hanger Hooks from cartoning.  
**Note:** Hanger hooks are found in the same box with the boards, in the open sleeve.

**Step 2:** Push Hanger Hooks over edge of board.

**Step 3:** Slide Hanger Hooks over corner trim.

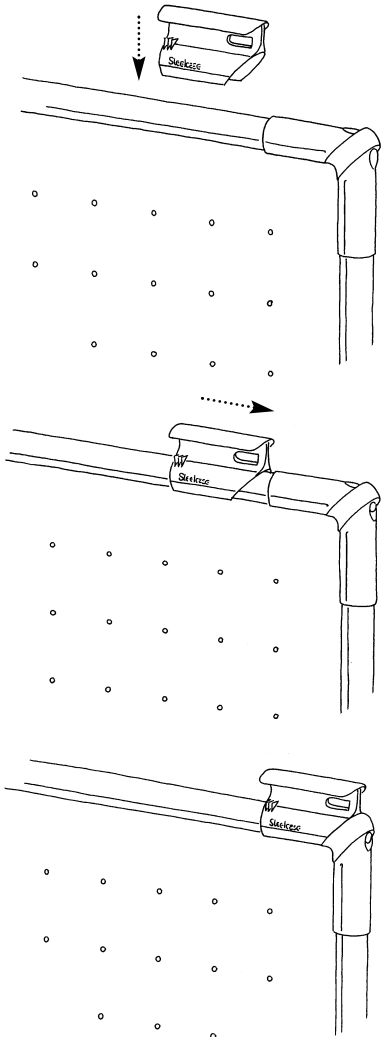

**Note:**  
 Huddleboard Boards are not designed to be ganged together.

**Maintenance**

Clean with warm soapy water, wipe with sponge and allow to air dry.

**Recommended Markers**  
 EXPO® dry erase markers from Sanford®.

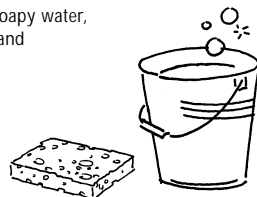
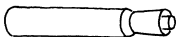

**Attaching Ledge Grabbers**

Slide the Ledge Grabbers over top of Hanger Hooks.

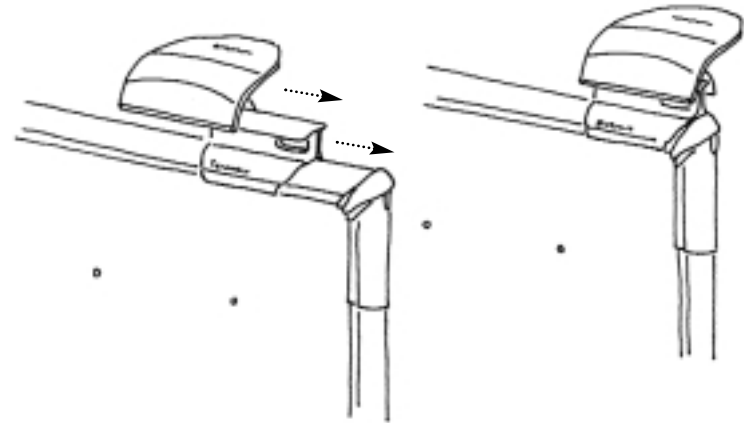

**Attaching Labels**

Write on Label. Peel from backing sheet and wrap over edge of board.

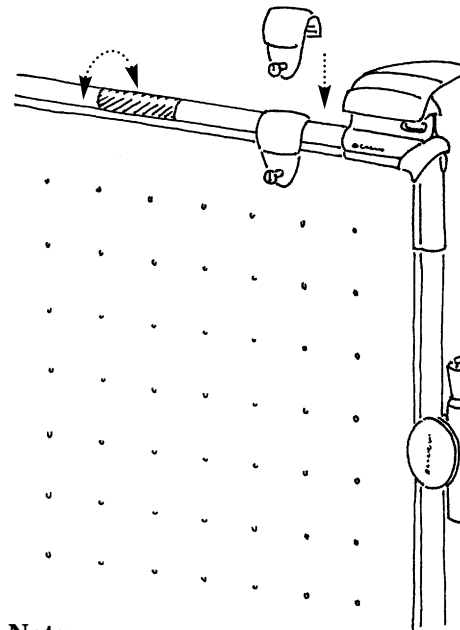
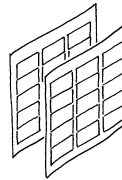

**Note:**  
 Accessory products are not to be used to gang boards.

**Attaching Flip Chart Pegs**

**Step 1:**  
 Push two Pegs over edge of board.

**Step 2:**  
 Position Pegs to fit holes in flip chart pad.

**Step 3:**  
 Attach pad.

**Note:**  
 Avoid stacking boards with Flip Chart Peg attached.

**Attaching Marker Grip to Board**

**Step 1:**  
 Slightly pinch Marker Grip and clip to edge of board.

**Step 2:**  
 Push Marker into Grip.

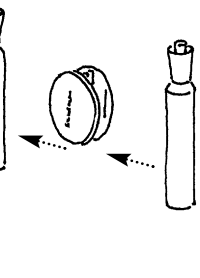

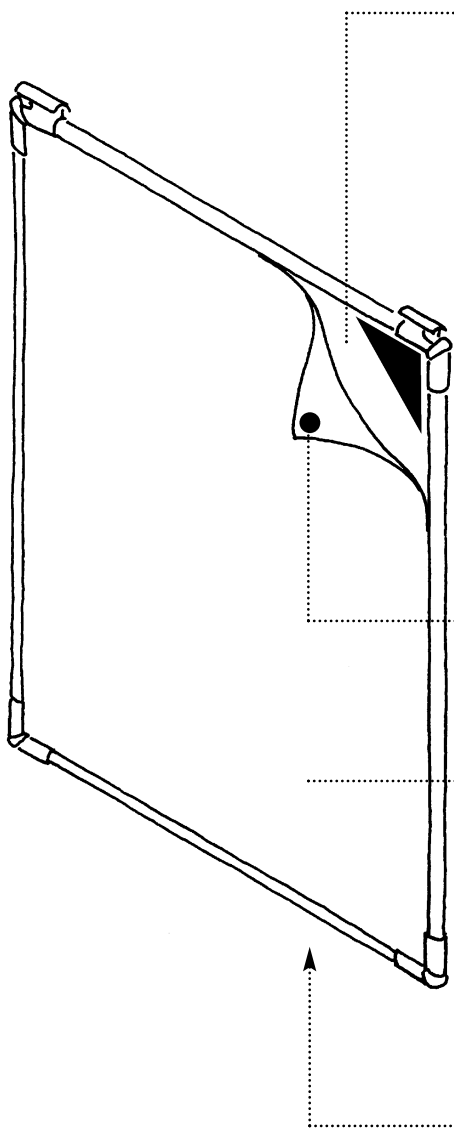

**Featuring a 3M repositionable adhesive used on Post-it® Brand products**

Adhere a variety of documents, charts, photos and more for display and interaction.

**Maintenance for adhesive surface**

Using a solution of warm sudsy water, dampen sponge slightly, dab soiled area and allow to air dry.

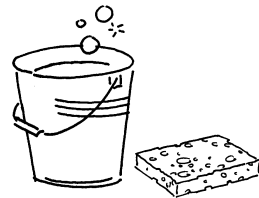

**Magnetic Corner Tab**

Helps secure cover over documents.

**Dry Erasable Cover Sheet**

**Recommended Markers**

EXPO® dry erase markers from Sanford®.

**Maintenance for cover sheet**

Sanford EXPO white board cleaner.

**Reverse side is Marker Board**

See instructions and maintenance on page 8.



The Huddleboard™ Photo Album lets you display and manipulate information without using tacks or pushpins. It has an adhesive surface with a transparent dry erasable cover sheet so you can annotate without messing up what's underneath. Turn it over, and you have another Marker Board –with a helpful dot grid, no less.

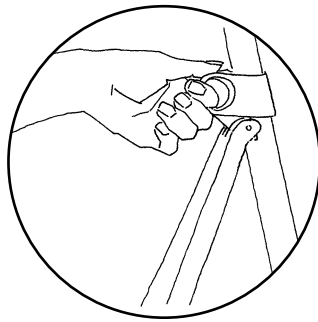
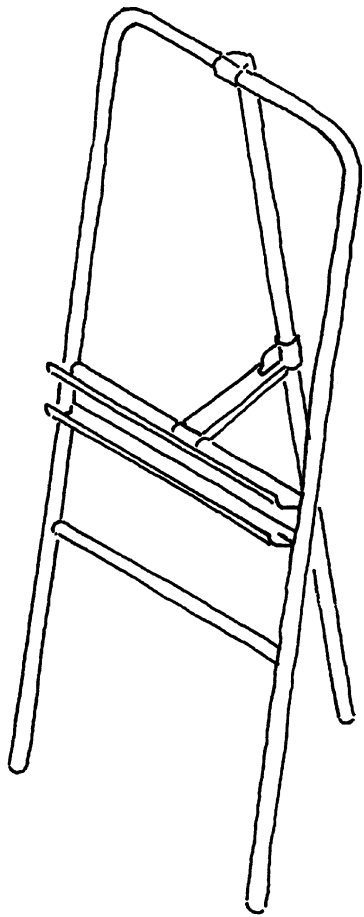

**Easy Pull Leg Prop**  
Folds flat for storage or portability.

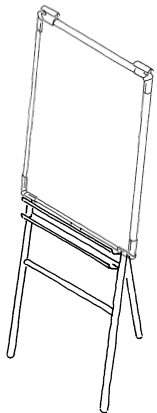

**Folding Easel**  
Has a tray capacity for 2 boards and supports both large and small size Marker Boards. Utility tray provides convenient place for markers and eraser.

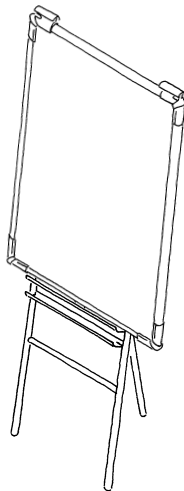

In a world that's increasingly  
"HIGH TECH,"  
Huddleboard Products are  
"NO TECH."

You don't need to sign up  
for a half-day seminar  
to be able to put them  
to work for you.

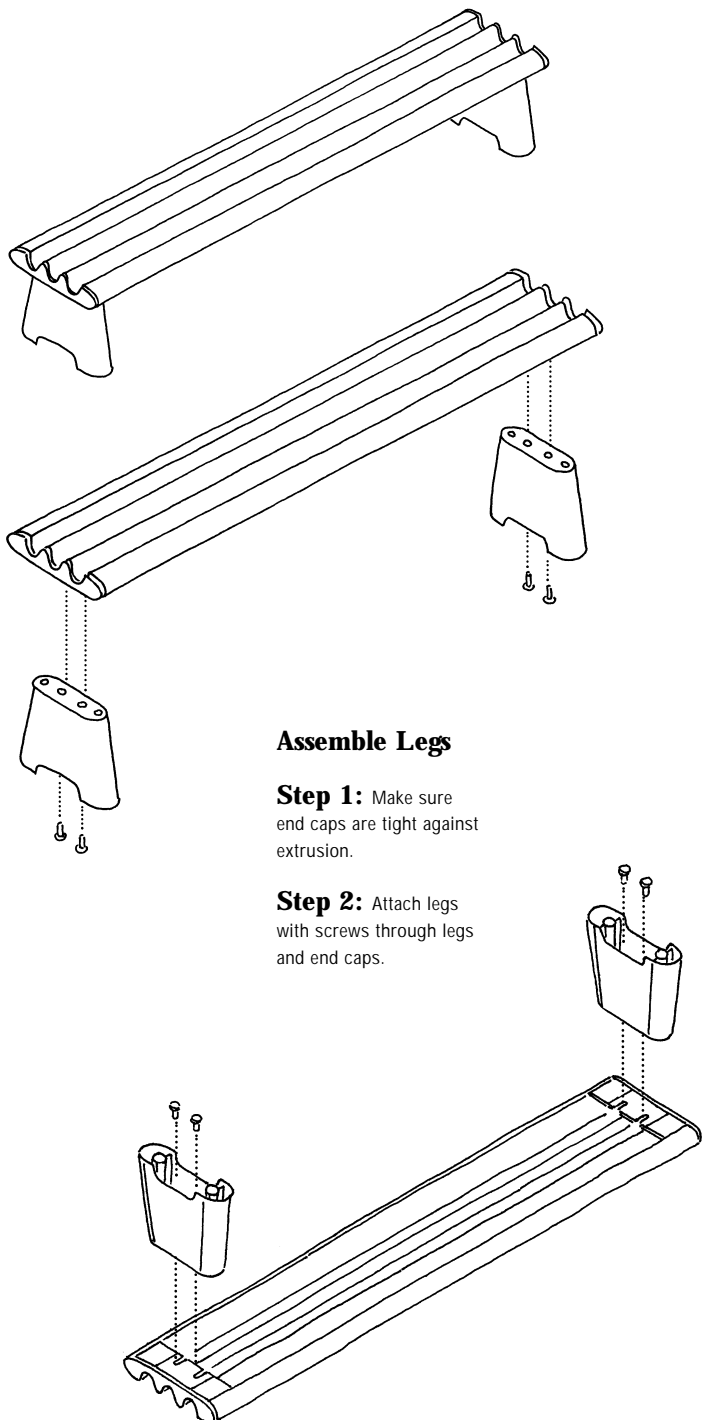

**Assemble Legs**

**Step 1:** Make sure end caps are tight against extrusion.

**Step 2:** Attach legs with screws through legs and end caps.

**Tray Assembly and Installation**

**Step 1:** Align and mount brackets **A** to respective panel or structural wall (drywall).

**Note:** For Pathways and Architectural mountings, mount brackets **A** 6" inboard to the end of tray location. For all other panel systems, mount brackets at desired height.

**Step 2:** Slide end caps **B** on both ends of tray **C** and fasten with screws.

**Step 3:** Position assembled tray **C** on brackets **A** and attach with screws.

**Note:** For Pathways mounting, slide brackets **A** inward/outward to ensure hooks fully engage.

**Note:** For 72" tray assemblies, 4 sets of brackets are required to support tray.

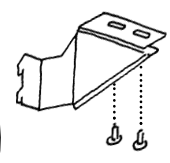
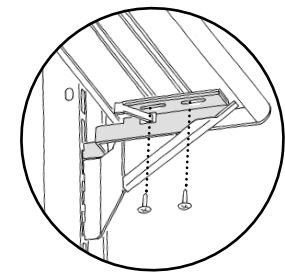
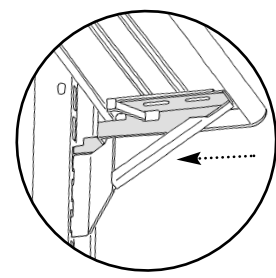
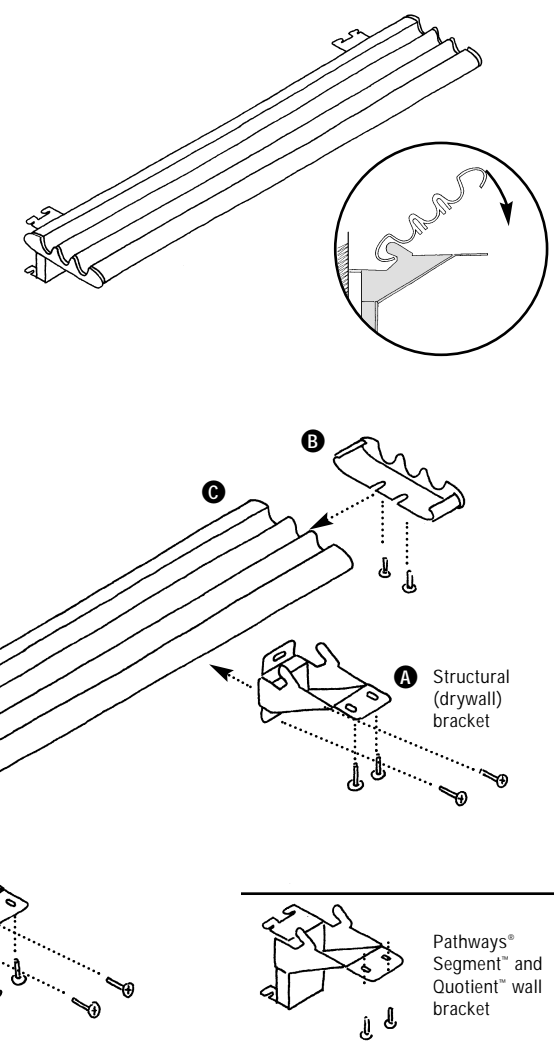

Detail of locking tab for Avenir and Series 9000 bracket. Lock bracket into panel, position assembled tray and attach with screws.

Avenir®, Series 9000® and Answer® bracket



**10 Board Storage Capacity**  
2 boards can be displayed on Sub-Board while the Easel Rack can store 10 more.

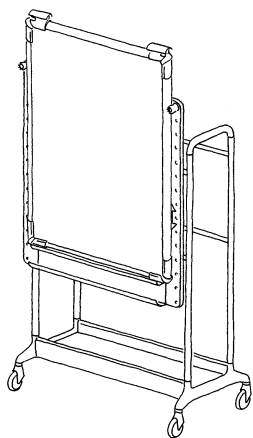

**Large Boards**  
Can be mounted horizontal and vertical.

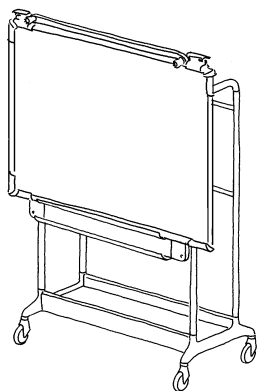

**Mobile Easel Assembly**

**Step 1**

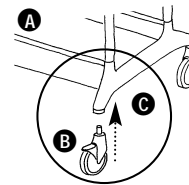

**Step 1:** Remove Easel **A** from box and press casters **B** into base **C** (a rubber mallet may be necessary). **Note:** If locking caster option is included, install locking casters in the two front positions.

**Step 2**

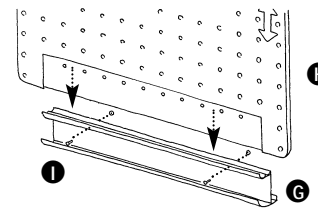

**Step 2:** Remove tray **G** from sub-board **H** by removing screws **I** and sliding tray off board.

**Step 3:** Angle sub-board **H** to engage upper brackets **D** and then rotate until vertical.

**Step 4:** Align sub-board to lower brackets **D** through rectangular window in sub-board **I**.

**Step 5:** Slide sub-board downward to fully engage to easel.

**Step 6:** Assemble tray **G** with screws, washers and nuts.

**Step 3**

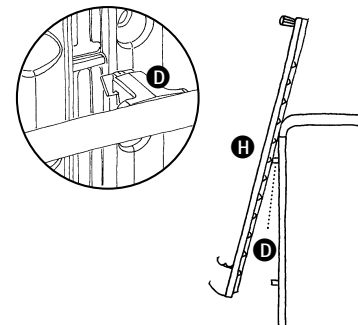

**Step 5**

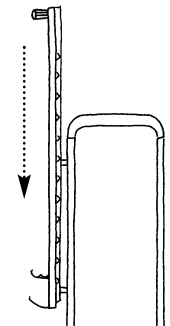

**Step 4**

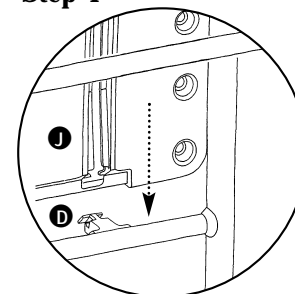

**Step 6**

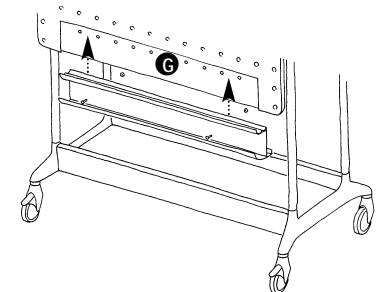

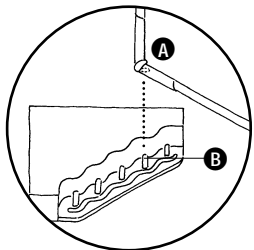
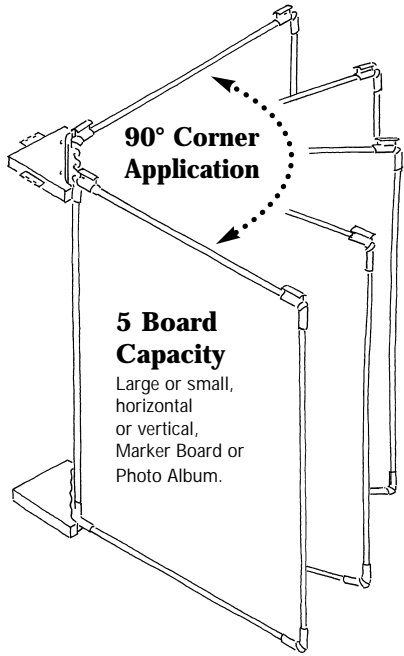

Bottom Assembly

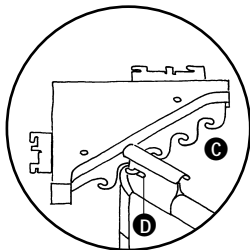

Top Assembly

**Attach Board to Poster Rack**

**Step 1:** Align hole in board corner **A** with pin **B** on bottom rack, snap in place.

**Step 2:** Attach top of board by sliding hook of rack **C** into hanger slot **D**.

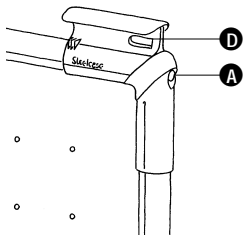

**Mounting to Structural Wall (Drywall)**

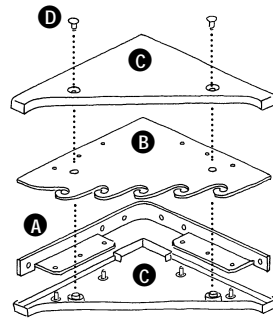

Top Assembly

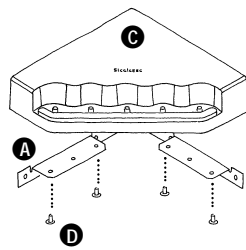

Bottom Assembly

**Step 1:** Using drywall screws, attach top and bottom mounting brackets **A** at correct height and spaced apart for board size and orientation.

Board Size & Orientation	Dim (hole to hole)
Small (horz)	23.73"
Small (vert)	32.23"
Large (horz)	32.23"
Large (vert)	42.23"

**Step 2:** Attach plate **B** to top bracket **A** and fasten with screws **D**.

**Step 3:** Align top and bottom covers **C** and fasten with screws **D**.

**Note:** Do not over tighten screws.

**Mounting to Pathways® Segment™ and Quotient™**

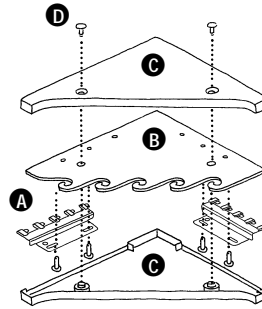

Top Assembly

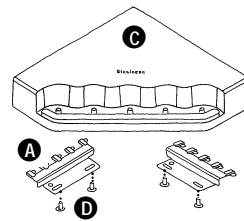

Bottom Assembly

**Step 1:** Hang top and bottom mounting brackets **A** inside corner panels at correct height spaced for board size and orientation. **Note:** Certain applications may require the hooks on the mounting brackets to be removed.

**Step 2:** Attach plate **B** to brackets **A** and fasten with screws **D**. **Note:** Make sure hooks are fully engaged.

**Step 3:** Align top and bottom covers **C** with plate **B** and fasten with screws **D**. **Note:** Do not over tighten screws.

**Note:** Pathways Segment and Quotient Walls require Poster Rack to be oriented vertically on 84" wall when large Marker Boards are used. All other Segment and Quotient wall applications less than 84" height allow only small board to be used in horizontal orientation.

**Mounting to Answer®**

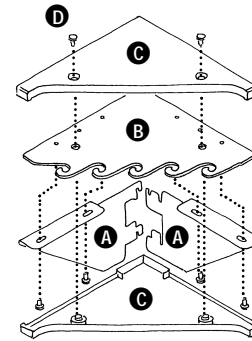

Top Assembly

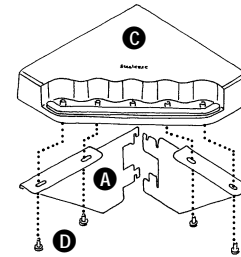

Bottom Assembly

**Step 1:** Hang top and bottom mounting brackets **A** inside corner panels at correct height and spaced apart for board size and orientation.

**Step 2:** Align plate **B** to brackets **A** and fasten with screws.

**Step 3:** Align covers **C** with plate **B** and fasten with screws. **Note:** Do not over tighten screws.

**Mounting to Avenir® and Series 9000®**

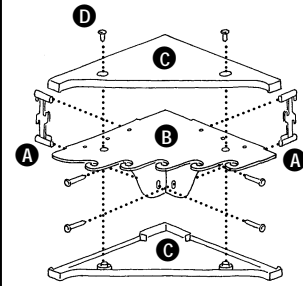

Top Assembly

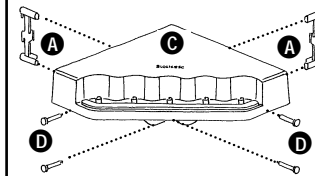

Bottom Assembly

**Step 1:** Hang top and bottom mounting brackets **A** inside corner panels at correct height and spaced apart for board size and orientation.

**Step 2:** Attach corner plate **B** to brackets **A** with screws **D**.

**Step 3:** Align covers **C** with plate **B** and fasten with screws. **Note:** Do not over tighten screws.

**Note:** Mounting bracket **A** rotates 180° for use either with Avenir or Series 9000 application. The short side for Series 9000 and the deeper for Avenir.



If you have a question, call your local dealer or

**1-888-STEELCASE**

8am-5pm E.S.T. M-F

[steelcase.com](http://steelcase.com)

**Steelcase®**