

Stella Mechanism

Primary Customer Need:

A readily adjustable keyboard support mechanism that is easy to operate, will work with a wide variety of support platforms and provides exceptional stability.

User Requirements:

- A simple-to-use keyboard support mechanism which provides superior stability
- Must be applicable to any furniture system and a wide variety of workstation settings

Product Features:

- Style Numbers: CMCSQ Standard Stella
 CMCEQ Extended Stella
 CSFMSS Standard Stella, Fixed Mount
- Size: Standard Track Length – 18³/₄" (requires 20" worksurface depth clearance)
 Extended Track Length – 23³/₄" (requires 25" worksurface depth clearance)
- Color: Black only
- Construction: Arm is cast aluminum. Track is steel.
- Application: Use in straight or corner configurations
- Warranty: 10 years
- Unique cable-controlled mechanism provides patented, knob-free adjustability.
- Applicable to either wood or metal surfaces.
- Ideal for intensive computer user or multi-user workstation.
- Mechanism Height Range: 8¹/₄" travel range, 2" above the worksurface to 5" below. Height is activated by tilting the support platform rearward approximately 3°, positioning the unit at the desired height and releasing. The unit will stay at the desired height until repositioned.
- Degrees of tilt angle possible: Between +/-15°. Tilt is activated by pressing button located on underside of the tray, center.
- Tilt angle is remembered by mechanism after each height adjustment.
- Fixed mount mechanism does not rotate.
- Product meets or exceeds all applicable BIFMA test standards.

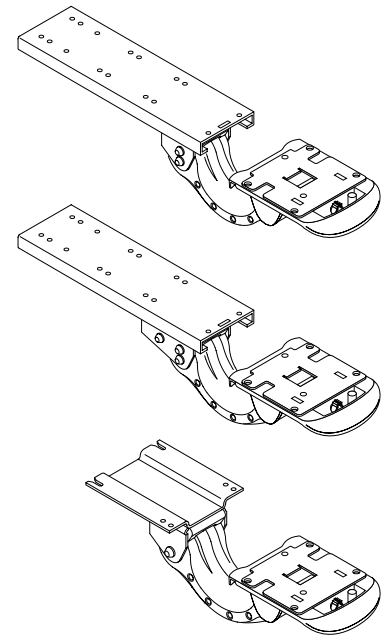

For a better day at work.™

details®

A STEELCASE COMPANY

www.details-worktools.com
P.O. Box 1967 Grand Rapids, MI 49501-1967
All rights reserved. Printed in U.S.A. 3/05